



**MEDIUM VOLTAGE VERTICAL MOTORS**

**TM21-VLL series**

**650 kW ~ 6,500 kW (870 HP ~ 8,700 HP)**



5050 kW, 20P, 280-E21 Motor

# TM21-VLL series

Combining over 100 years experience with innovative new technology makes the TM21-VLL series the right choice for the demanding needs of today's industry.

## Quality

- Rugged, high quality fabricated plate steel construction
- ISO9001 Series Certification

The large capacity series (VLL) has been added to the TM21-L vertical line of motors

## Performance

- Standardized Frame
- Custom Frame is available

## High reliability

- Meets worldwide standards
- Improved insulation helps withstand high surge

## Features/Benefits

TMEIC's standard structure design meets customer's requirements

### Wide Range of Thrust Bearings

**Bearing selection is based on the speed and thrust load**

- Angular contact ball bearings (self-cooled)
- Spherical roller thrust bearings (self-cooled, air-cooled, water-cooled, oil-cooled)
- Tilting pad thrust bearings (air-cooled, water-cooled, oil-cooled)

### Excellent Electrical Performance

**Individual designs are available upon request**

- Efficiency, power factor, starting current limit, torque characteristics, etc.
- May be tailored to meet customer requirements

### Lower Noise & Lower Vibration

- The latest technology reduces vibration and noise
- Noise level: 80dB(A) and lower (design value) JEC-2137/IEEEE85 at no load 1 m 4 points average
- Vibration level: 1.8 mm/sec on bearing bracket. IEC60034-14 Grade B at no load (design value)



### Analytical Technology Improves Design

- Electromagnetic field analysis
- Heat conduction analysis
- Air flow system analysis

### Advanced VPI Insulation System

- Improved insulation withstands higher surge
- Inverter drive operation is an option

### Type of Protection & Cooling Method

**Customized enclosures allow a standard production motor to meet individual requirements**

- Drip-proof, NEMA Weather Protected
- Totally enclosed air-to-air cooled
- Totally enclosed water-to-air cooled

### Excellent Quality Control

- Designed for inspector/operator safety
- Bearing lubricant cycle extended and maintenance lowered with standard tilting pad thrust bearing

# TM21-VLL Series Features of

## High Reliability & Easy Maintenance / Operation

### Upper bearings

A selection of thrust bearings from low to high load, customized for the application  
Non-reversing ratchet is an option

### Stator

Stator core's segment split core is robotically manufactured for precise structure and less core loss

Bolted iron core produces solid structure, reducing manufacturing time

### Rotor

Fabricated copper rotor bars seated against core slots with full length swedging

Rotor bar shape optimizes starting torque current characteristics for pump applications

Rotor spider shrunk-fit to shaft with key when used with a forged shaft

Rotor rib welded to shaft when used with a hot rolled steel shaft

### Modular coolers

Cooler for totally enclosed water-to-air motor uses deoxidized copper tube suitable for standard industrial water. Cu-Ni tube, etc. is available for more severe conditions

Not shown - air-to-air coolers (IP55) with severe duty stainless steel tubes and standard open air circuit coolers - ODP/WPII (IP23/IP24W)

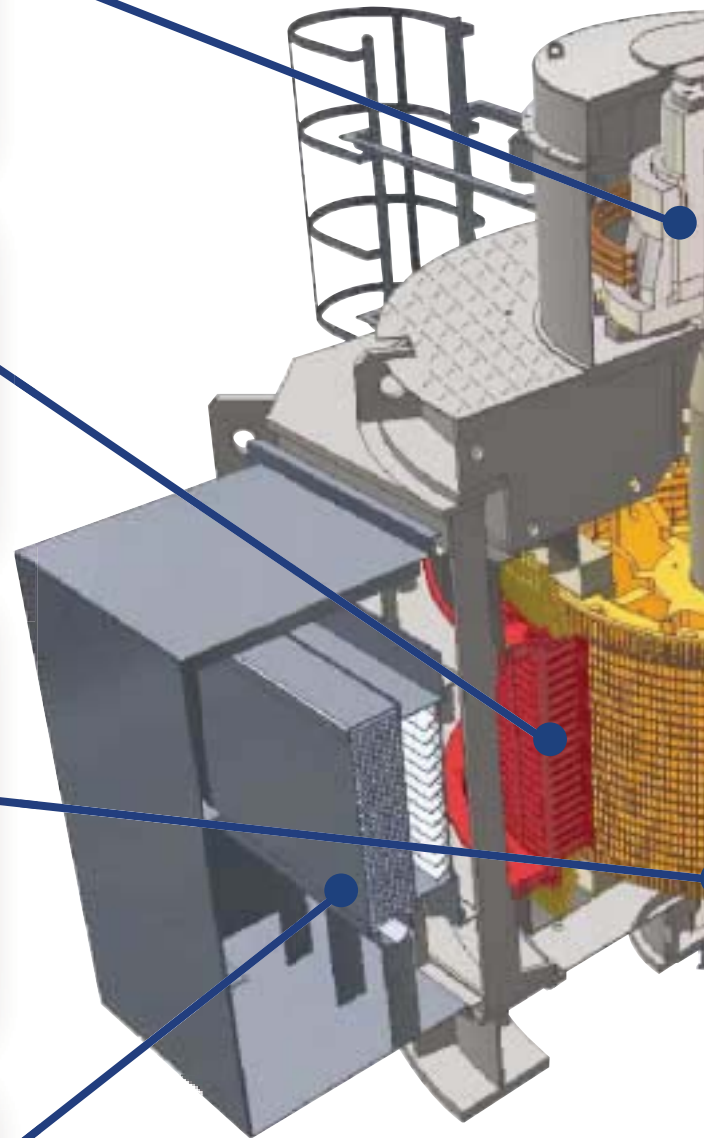



# Vertical Motors

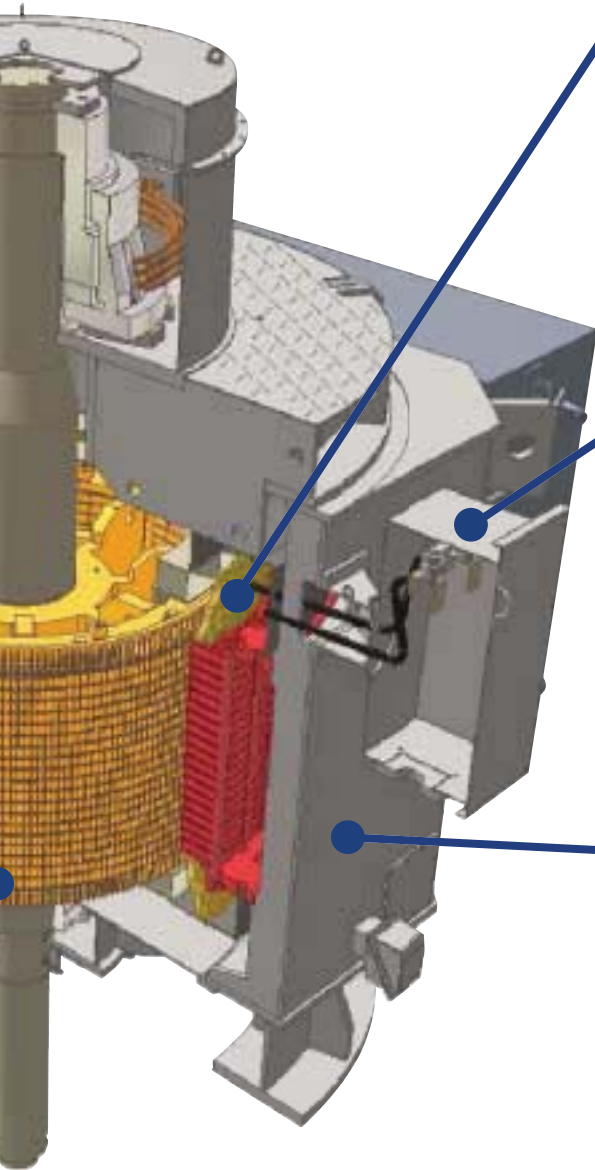

## Stator coil

The reliability of TMEIC's vacuum pressured impregnation insulation has been proven with the conventional series

Powerful support structure established with strength analysis of the coil end and heat cycle testing

## Terminal box

Standard main terminal box can be rotated at 90° intervals

Adequate space for cable connection

Separate auxiliary boxes standard

Stand-off insulator facilitates strong lead connections

## Stator frame

Unique frame shape developed through FEM analysis results in a stiffer frame with reduced vibration and improved efficiency

Data analysis of the natural resonance frequency to help avoid vibration with the pump frame is available

## Safety

Ladder access plates

Warning labels

Ample grounding

Non-skid top plate

Touch-safe IEC terminal blocks for auxiliary terminal box

# Technology that leads the world

- Outstanding electric & mechanical characteristics lower operating costs
- The special frame structure helps attain low noise and vibration
- Highly reliable Vacuum Pressure Impregnation (VPI) insulation protects against sudden surge voltage
- Adjustable speed control drive is an option
- Maintenance and transport issues considered during design

## Series Motor Enclosures

### NEMA Weather Protected

This motor (IP24W, IC01) is designed for outdoor operation. The air housing is in accordance with NEMA WP11, and features three right-angled turns for air intake. Air velocity in one section falls below 3 m/sec (600 ft/min), trapping water, dust, and foreign materials. A section is provided that allows air to pass through without being forced into the motor.

**Indoors and Outdoors**

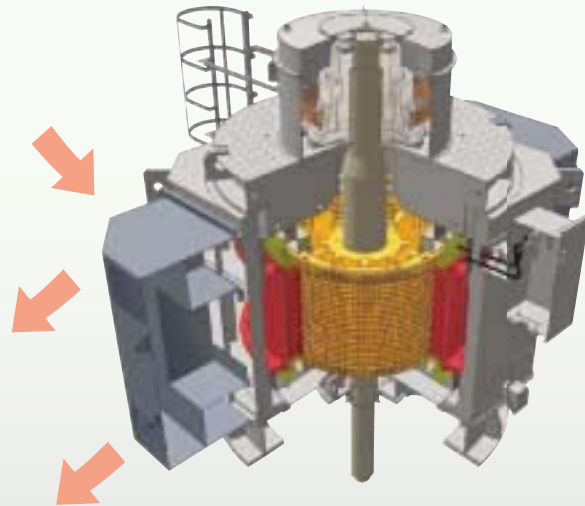

### Totally Enclosed Air-to-Air Cooled

In an environment containing corrosive or harmful gas, a totally enclosed air-cooled motor (IP55/IC611) is generally used. The external fan mounted on the opposite drive end directs fresh air into the pipes of the air housing located on the upper part of the motor. The pipes constitute a heat exchanger in which fresh air passing through cools the hot air.

**Dusty and Severe Environments**

For low maintenance & high degree of protection

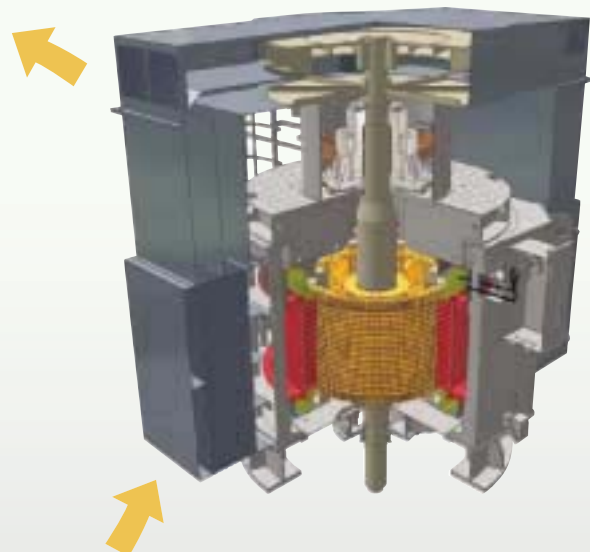

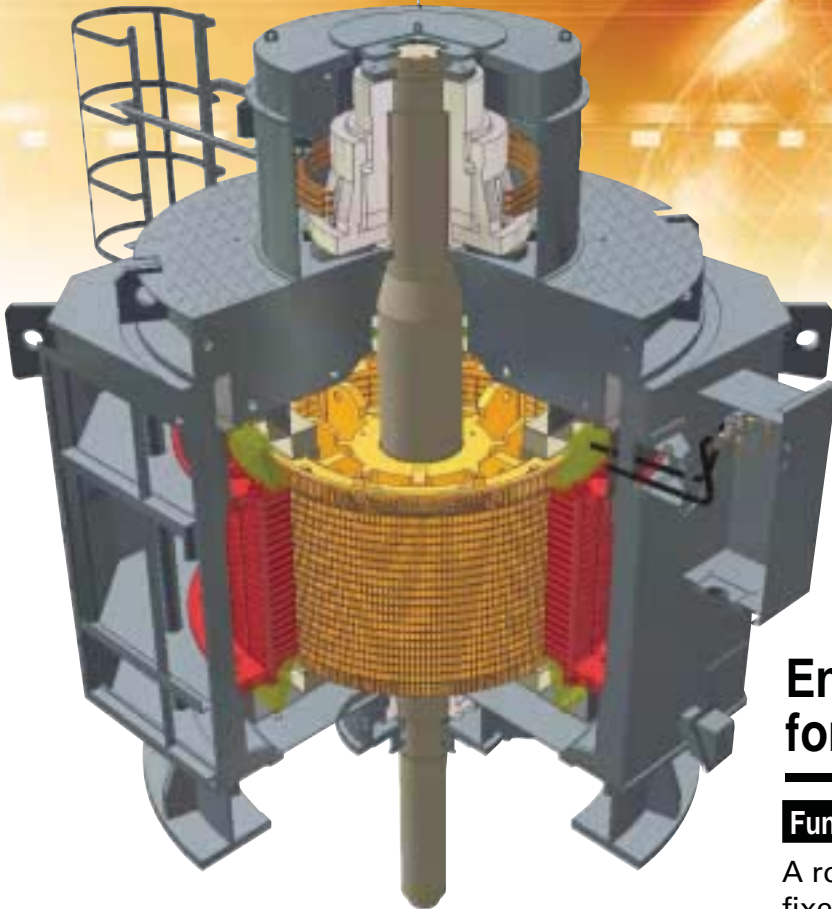

## Enclosures customize the motor for a variety of environments

### Fundamental structure

A round flange under the semi-square frame is fixed to the pump frame

Air housing mounted on left and right sides (viewed from the main terminal box mounting side)

Large terminal box makes connecting power cables easy

Upper bearings match the thrust level; standard bearing insulation prevents shaft current

### Totally-Enclosed Water-to-Air Cooled

This type of motor (P55, IC18W) is especially useful in a location where low noise operation is required or where it is desired to remove heat from the motor.

Air housings on both sides of the motor accommodate air-to-water heat exchangers.

A drain in the air housing protects the motor from damage caused by water leakage.

**For quiet environments**

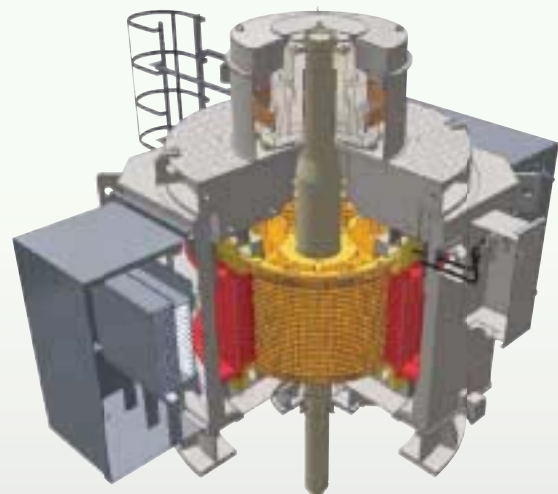

# TM21-VLL VERTICAL MOTOR SERIES

Output:	Designs from 650 kW to 6,500 kW (870 HP ~ 8,700 HP)
Number of poles:	12, 14, 16, 18, 20, 22, 24, 26, 28 (Option: more than 30)
Frame size:	228-E15, 265-E18, 280-E21, 330-E24*
Voltage:	3 kV~13.8 kV
Frequency:	50 or 60 Hz (Adjustable speed with an inverter is an option)
Insulation:	VPI insulation system (heat resistance class F, temperature rise limit B or F)
Locked rotor:	550% (typical)
Enclosure:	Totally Enclosed Air-to-Air Cooled (TEAAC), Totally Enclosed Water-to-Air Cooled (TEWAC) Open Drip-Proof (ODP/WPI), NEMA Weather Protected (WPII).
Protection	IP23, IP24, IP44, IP54, IP55, etc.
Explosion proof:	<ul style="list-style-type: none"> <li>• Non-sparking (NEC Non Sparking / Ex-n: Option)</li> <li>• Increased safety (Ex-e: Option)</li> <li>• Inner pressurized (Ex-p: Option)</li> </ul>
Mounting:	Vertical with flange
Bearings:	Angular contact ball bearing, Spherical roller bearing, Tilting pad thrust bearing
Standards:	JEC, JIS, IEC, IEEE/NEMA, BS, AS, API-541, CSA (Other standards are also available)
Noise:	80dB(A) and Lower (Design Value); JEC-2137/IEEE85 at No Load 1m 4 points average Low noise design is applicable with silencer (Option) *Motor noise is 80dB(A) or less with standard silencer

## \*Explanation of Frame size

ex. 228 - E15  
(1) (2)

(1) : One-tenth of the installation bolt circle pitch diameter. ( $\phi B$  in the following figure)

(2) : Size of frame: 4 Frame sizes: E15, E18, E21, E24

## Extra large vertical model installation dimensions (mm)

	E15	E18	E21	E24
Flange outer diameter $\phi A$	2400	2800	3000	3550
Mounting pitch diameter $\phi B$	2280	2650	2800	3300
Flange inner diameter $\phi C$	1800	2120	2350	2600
Number of mounting bolt holes N	20	24	24	24
Bolt hole size $\phi E$	48	56	56	56
Flange thickness D	50	55	55	55
Frame No. nominal	228-E15	265-E18	280-E21	330-E24

Adaption to the existing installation dimensions is available.

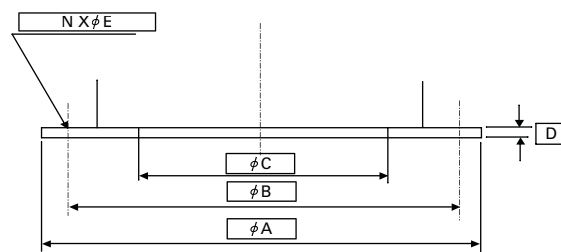

Motor Flange Standard Size



# TM21-VLL Series Basic Construction detail

21-VLL

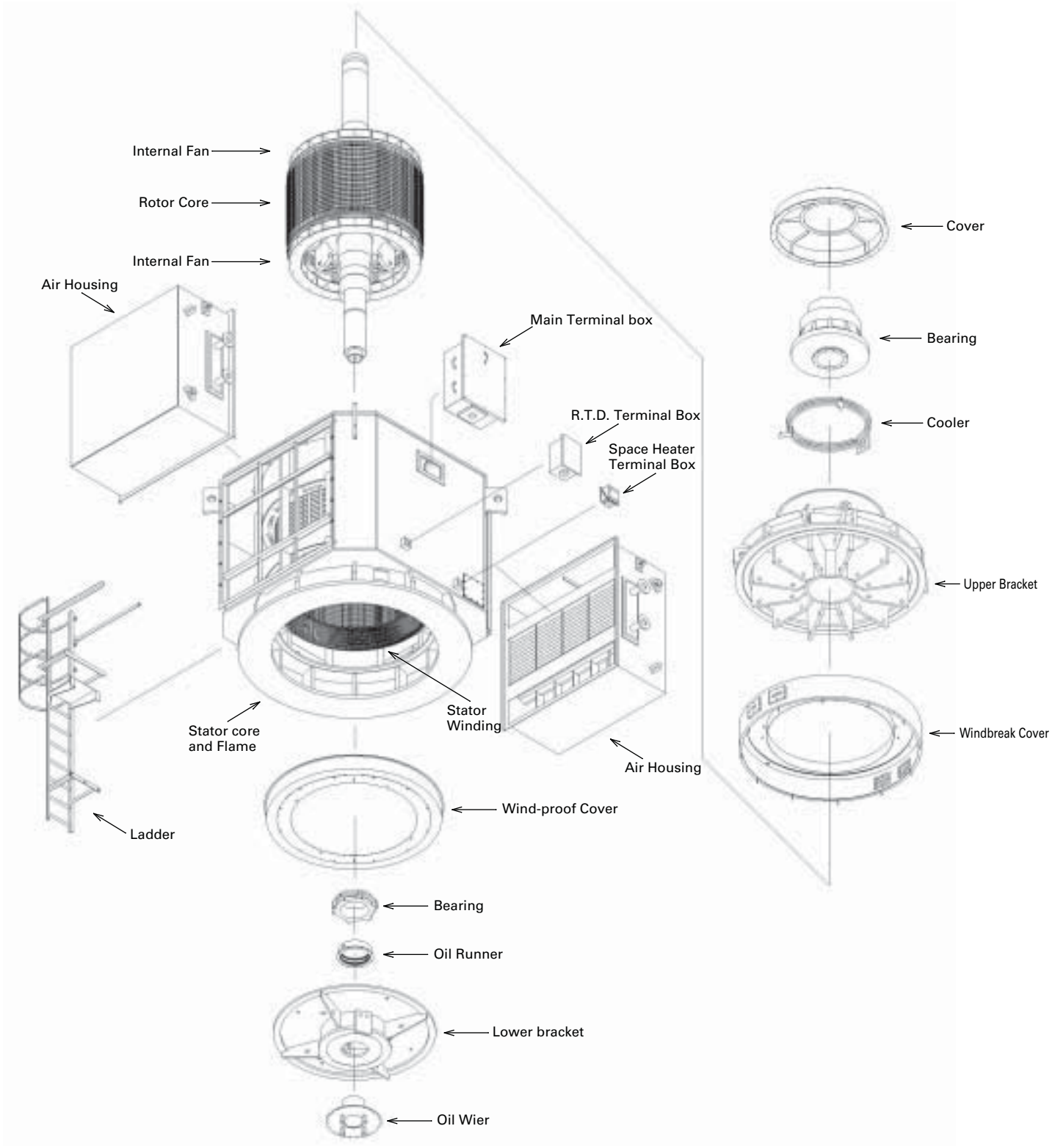

# BEARING CONSTRUCTION TYPES

## A Selection of Thrust Bearings to meet individual requirements

### Upper bearing details (1)

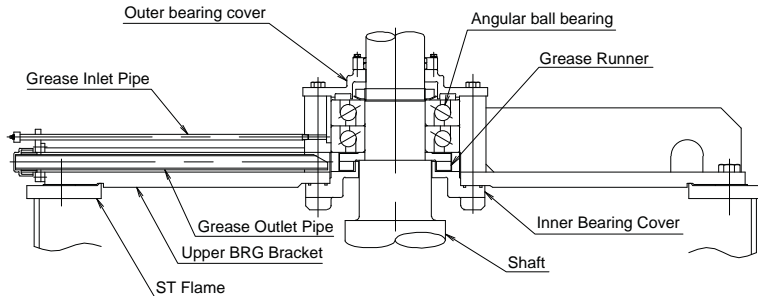

#### Angular contact ball bearing

- Lubricant: Lithium grease
- Cooling system: Radiant self-cooled
- Use for NONE or low down thrust

Over 35,000 hours\* life and 5,000 hours re-greasing interval with large bearing

\*L10 Life

### Upper bearing details (2)

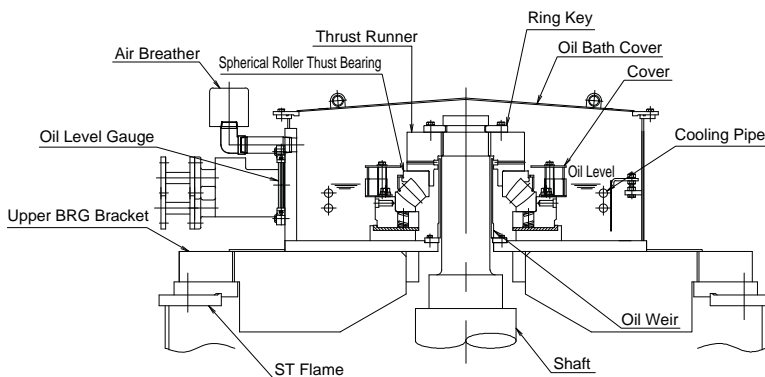

#### Spherical roller thrust bearing

- Lubricant: Turbine oil (VG46)
- Cooling system: Radiant self-cooled  
Air-cooled (shaft mounted fan)  
Water-cooled
- Medium to high down thrust

### Upper bearing details (3)

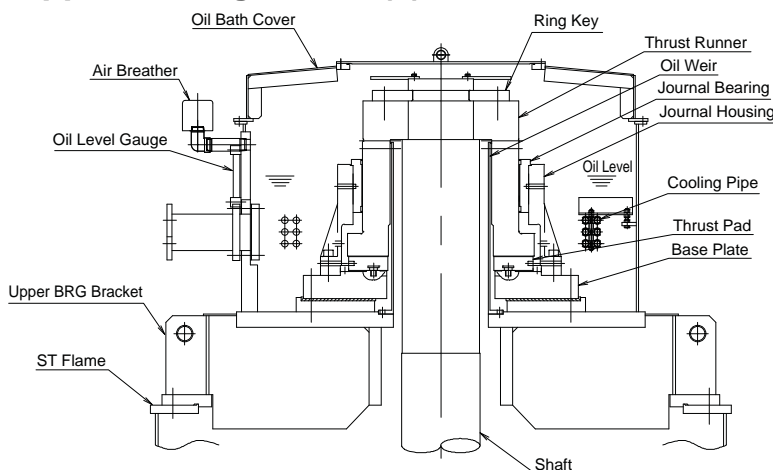

#### Tilting pad thrust bearing

- Lubricant: Turbine oil (VG46 or VG68)
- Cooling system: Air-cooled (shaft mounted fan)  
Water-cooled  
Oil-cooled
- Use for high down thrust

## Guide line of upper thrust bearing selection

Allowable continuous down thrust

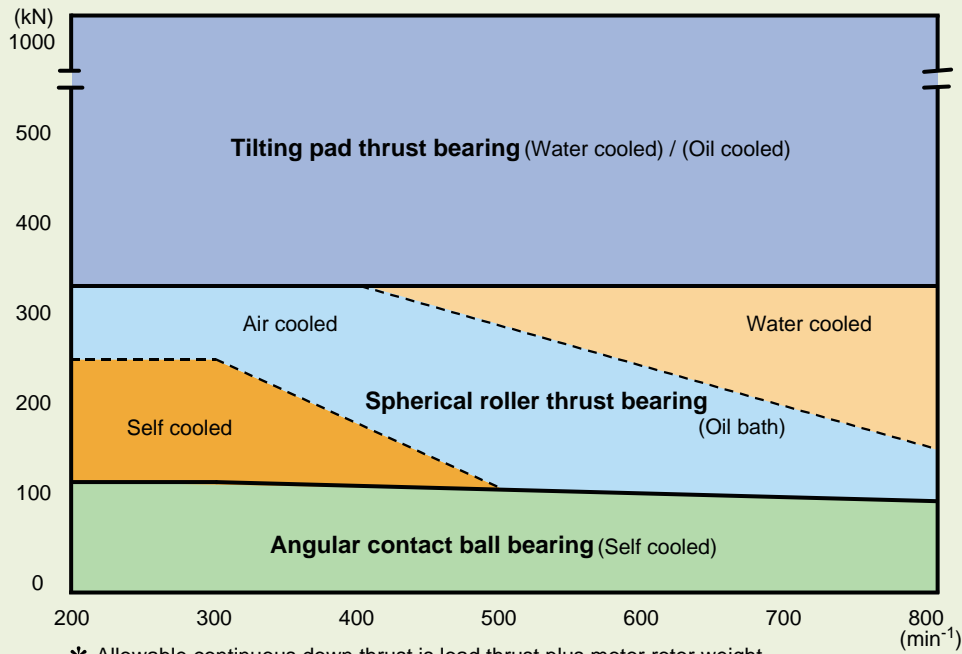

- \* Allowable continuous down thrust is load thrust plus motor rotor weight.
- \* Allowable maximum momentary (up to 30 seconds) down thrust is 1.5 times continuous down thrust.

### Lower bearing details (1)

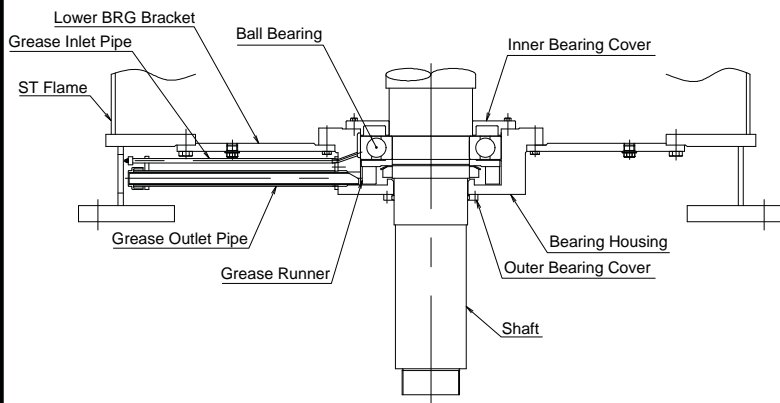

#### Antifriction ball bearing (Grease lubrication)

- Lubricant: Lithium grease
- Cooling system: Radiant self-cooled

Applicable condition:  
 Max. size bearing: 6248  
 Rated torque 58,000 Nm or less  
 Rated speed 800 min-1 or less

### Lower bearing details (2)

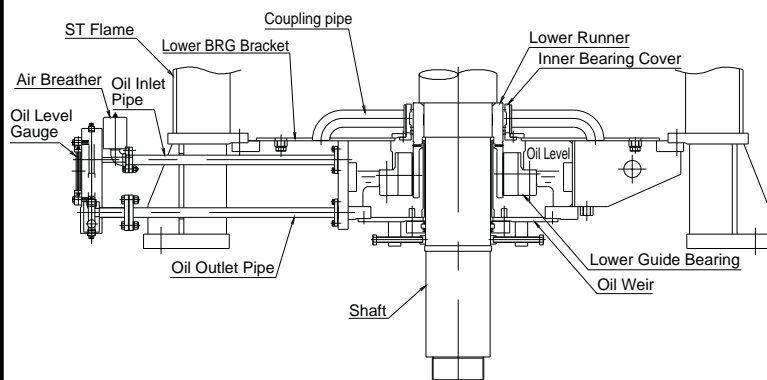

#### Sleeve bearing (Oil lubrication)

- Lubricant: Turbine oil (VG46 or VG68)
- Cooling system: Radiant self-cooled, Water-cooled

Applicable condition:  
 Use when applicable condition of the antifriction ball bearing or customer's specification is exceeded

# MAIN TERMINAL BOX

Size and Construction (~11 kV class)

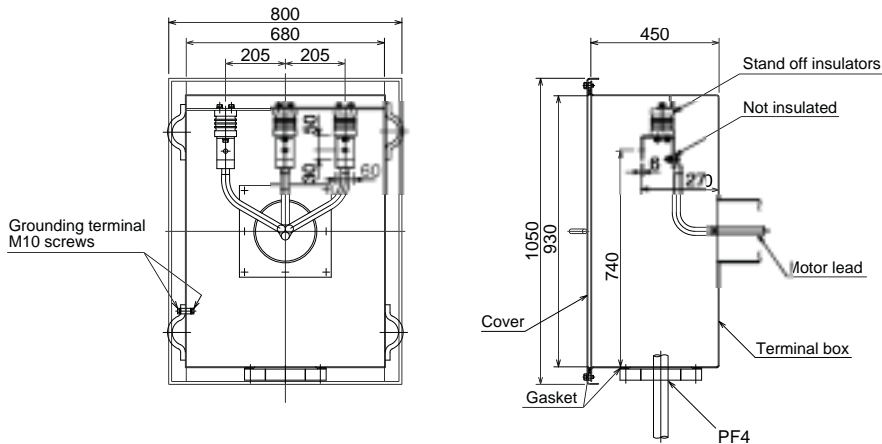

# AUXILIARY TERMINAL BOX (Standard)

Size and Construction

R.T.D.

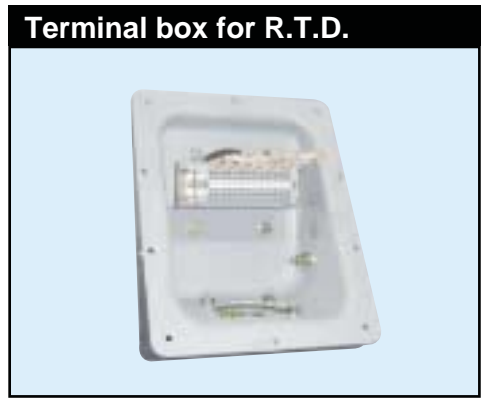
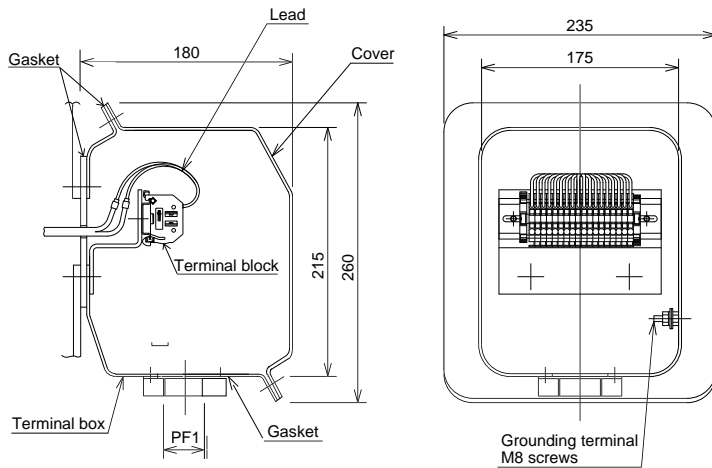

# Space heater

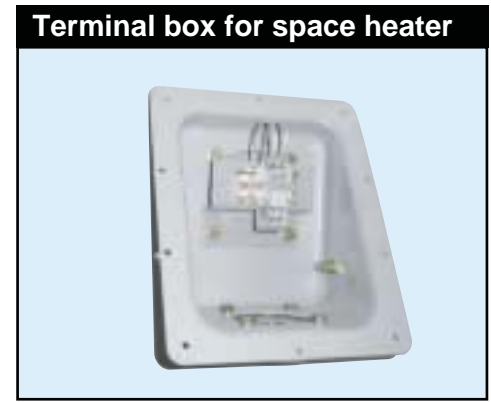
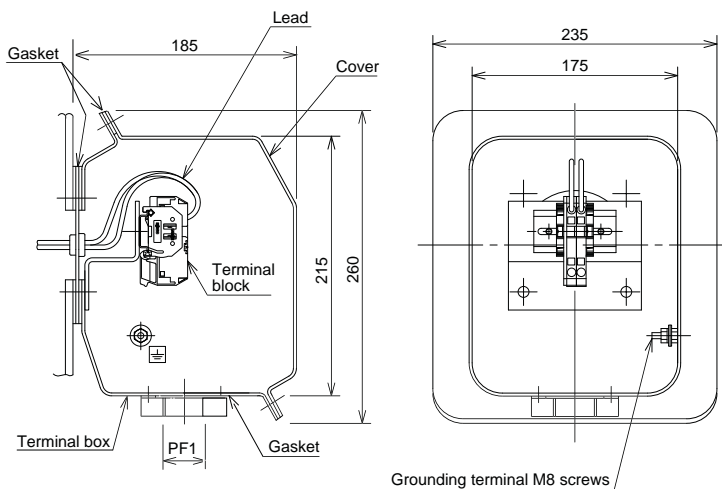



# ACCESSORIES

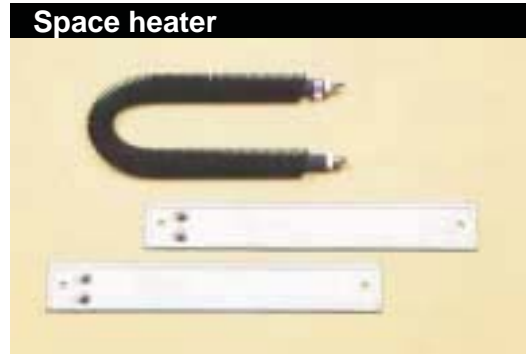
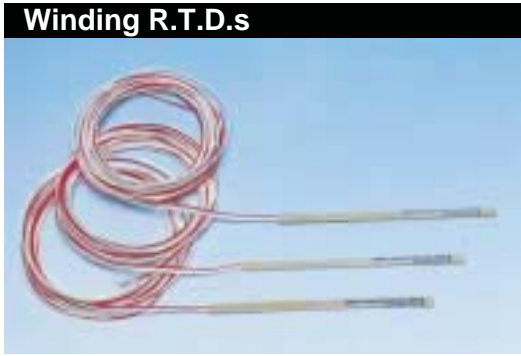

## Optional Non-Reversing Ratchet Details

A non-reversing ratchet is an option  
 (Long lifetime with frequent reverse torque over 10,000 applications)

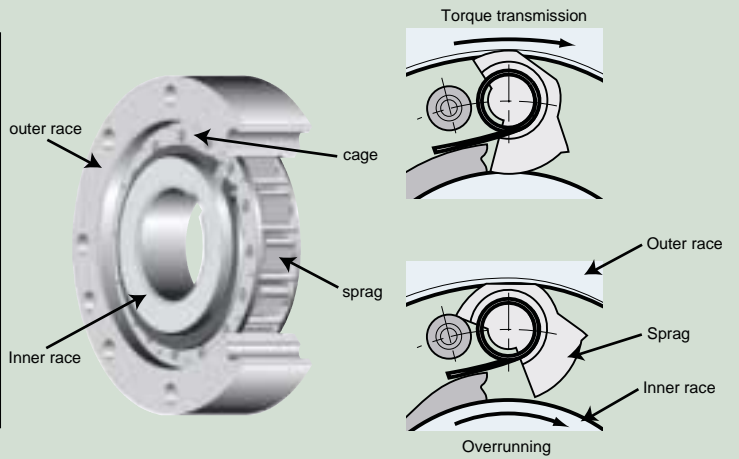
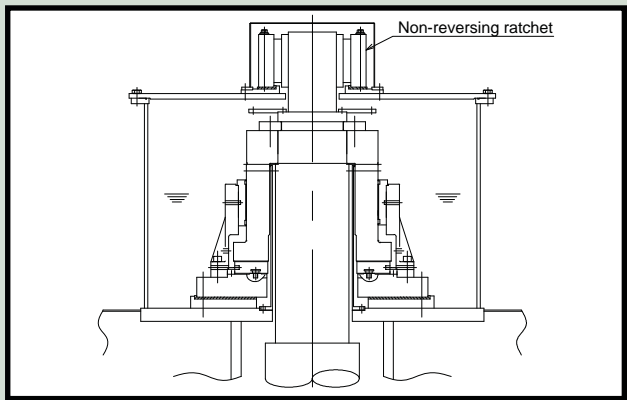

# Standard Specifications

Item	Standard Specifications	Remarks								
Rated Output Power	650 kW – 6,500 kW, depending on the number of poles	Cooling method may affect output range: IC611TEAAC: 5,000 kW max. output IC81WTEWAC: 6,500 kW max. output IC01 ODP: 6,500 kW max. output								
Rated Voltage	3,000 or 3,300 4,000 or 4,160 6,000 or 6,600 10,000 or 11,000	Options: 2.3 kV, 2.4 kV, 13.2 kV, 13.8 kV Selection in the range shown is economical  Table 1 <table border="1" style="margin-left: 20px;"> <thead> <tr> <th>Voltage Class</th> <th>Recommended Output</th> </tr> </thead> <tbody> <tr> <td>3 kV</td> <td>Up to 4,000 kW</td> </tr> <tr> <td>6 kV</td> <td>From 1,000 to 6,500 kW</td> </tr> <tr> <td>11 kV</td> <td>3,000 kW and larger</td> </tr> </tbody> </table>	Voltage Class	Recommended Output	3 kV	Up to 4,000 kW	6 kV	From 1,000 to 6,500 kW	11 kV	3,000 kW and larger
Voltage Class	Recommended Output									
3 kV	Up to 4,000 kW									
6 kV	From 1,000 to 6,500 kW									
11 kV	3,000 kW and larger									
Frequency	50 Hz, 60 Hz	Adjustable speed with an inverter is an option								
Number of Poles	12 – 28 poles	8 poles, 10 poles or over 30 poles can be manufactured								
Applicable Standards Characteristic Performance Calculation  Materials Explosion Proof	IEC60034-1 (General) JEC or NEMA IEC60034-1 or JEC-2137 IEEE112 Method F or JEC-2137 JIS (Japan Industrial Standard)  For Hazardous area use, motor will be manufactured with Baseefa certification, except for Japanese users  Motor will be manufactured with TIIS Certification for Japanese users	Motors can be manufactured to meet NEMA, IEC, BS, AS or Japanese Standard JEC-2137  Exn: Non-sparking Exe: Increased safety Exp: Pressurized  eG3, eG2: Increased safety fG3, fG4: Pressurized								
Reference ambient temp.	Maximum: +40° C; Minimum: -20° C	Motors for high (50° C) or low (-50° C) temperature environments are available								
Installation site/ altitude	Sea level: 1000 m or less	Motors for high altitude can be manufactured								
Installation environment	Relative humidity: 95% or less  Non-hazardous environment	Indicate if the motor will be installed in a tropical location  Anti-corrosion treatment is required for use in atmospheres containing corrosive gases such as H <sub>2</sub> S (hydrogen sulfide)								
Insulation class	F temperature insulation	VPI (vacuum pressured impregnation) insulation system								
Temperature rise limit	Temperature rise limit of the stator windings when ambient temperature is 40° C uses B rise ETD method 85k <sup>(1)</sup> , 90K <sup>(2)</sup>	F class temperature rise is available  (1) more than 5,000 kW  (2) less than 4,000 kW								
Service factor	1.0 SF	1.0 SF (B-rise)/1.15 SF (F-rise) is an option								
Noise	80dB(A): design value (4 points average value)  Average acoustic pressure level 1m away from motor flat plane at the height passing through the approximate center of the stator frame during no-load test, noise level will be 80d(A) or less	A low-noise motor can be manufactured, depending on the number of poles, and size of the motor								

Item	Standard Specifications	Remarks
Protection/cooling system	Totally-enclosed type: IP55-IC611, IC81W Open drip-proof type: IP22, IP24-IC01	Protection and cooling methods may be selected in accordance to the installation conditions or environment
Starting duty (for pump use)	When starting from ambient temperature state (COLD state): three consecutive starts When starting after load operation and stopping the motor, starting from the rated load (HOT state): Two consecutive starts	
Starting method	Full voltage starting (Direct on line): normally considered $\pm 10\%$ voltage	Option - reduced voltage starting using reactor or auto-transformer Indicate permissible starting kVA
Bus transfer during operation	Bus transfer condition is not considered	An excessive current will flow due to the phase difference of the residual motor voltage Large transient torque will be generated, creating an unfavorable condition for the motor Indicate when a bus transfer is required
Rotation direction	Uni-direction is standard Bi-directional is an option	Motor with a non-reversing ratchet cannot be run in reverse
Shaft end	Single shaft extension; straight shaft with parallel key	If the fluxional torque value is large when starting or during operation, the key way and shaft dimensions may be changed
Cooling water for TEWAC motor	Cooling water: Temperature: Max. 35°C Shutoff pressure: Max. 0.7 MPa Water quality: Fresh water for industrial use Tube shape: Single tube with plate fins Tube material: Seamless phosphorus deoxidized copper tube (JIS C1220)	Indicate if supplied water temperature is higher than 35° C A double tube can be manufactured Water quality (polluted fresh water, sea water), determines tube material - tube material may be changed to Cu-Ni (JIS C 7060T), or higher grade material
Finished color	Munsell notation 2.5PB6/2	Other colors available
Paint coat thickness	Epoxy resin, Phthalic acid: 50 $\mu\text{m}$ or more;	Other thicknesses available
Accessories	Standard accessories include: Winding R.T.D.s (Pt-0°C-100): Qty. 6 Bearing R.T.D.s (Pt-0°C-100): Qty. 2 or 3 Space heater, maintenance ladder, simple platform, shaft end key, drain plug, grounding bolt	Other devices available as options: CT, surge arresters, surge capacitor, vibration detectors, dial thermometer, etc.
Test and Inspection	Factory tests carried out based on JEC-2137 or IEEE112, IEEE85 Standard test results are provided Insulation test (High voltage and insulation resistance) Characteristic calculation results Vibration measurement Temperature rise test (first unit only)	Performance criteria: Unless otherwise specified, the tolerance approved by IEC60034-1 or JEC-2137 will be applied to the guaranteed value Indicate when a witness test is required



**TOSHIBA MITSUBISHI-ELECTRIC INDUSTRIAL SYSTEMS CORPORATION**

Mita 43 Bldg, 13-16 Mita-chome, Minato-ku Tokyo, Japan

Tel.: +81-3-5444-3828

[www.tmeic.co.jp](http://www.tmeic.co.jp)

**TMEIC Corporation**

1325 Electric Road, Suite 200 Roanoke, Virginia, 24018, USA

Tel.: +1-540-283-2000

[info@tmeic.com](mailto:info@tmeic.com) • [www.tmeic.com](http://www.tmeic.com)

**TMEIC Corporation, Houston Branch**

2901 Wilcrest Dr., Suite 110, Houston, Texas, 77042, USA

Tel.: +1-713-784-2163

[OilGas@tmeic.com](mailto:OilGas@tmeic.com) • [www.tmeic.com](http://www.tmeic.com)